

MAZDA 6 2009

- 1 Disconnect the negative battery terminal to prevent an accidental short circuit.
- 2 Unclip and remove the cup holder/parking brake trim panel. (Figure A)
- 3 Unclip and remove the trim panel above the glove box and down the right side of the center console. (Figure B)
- 4 Unclip and remove the trim panel next to the key switch and down the left side of the center console. (Figure B)
- 5 Unclip and remove the trim panel surrounding the climate controls and the shifter lever. (Figure C)
- 6 Unclip and remove the vent panel above the radio. (Figure D)
- 7 Remove (4) screws securing the factory radio. Unplug and remove the radio.

Continue to kit preparation

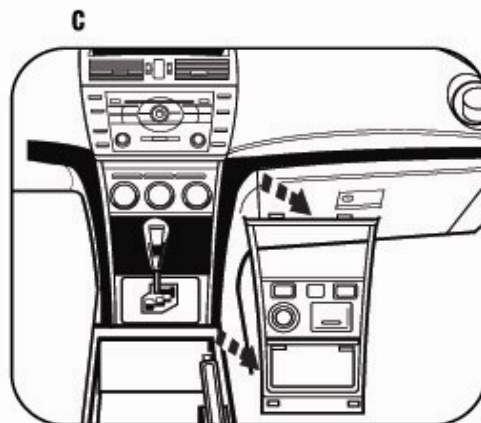
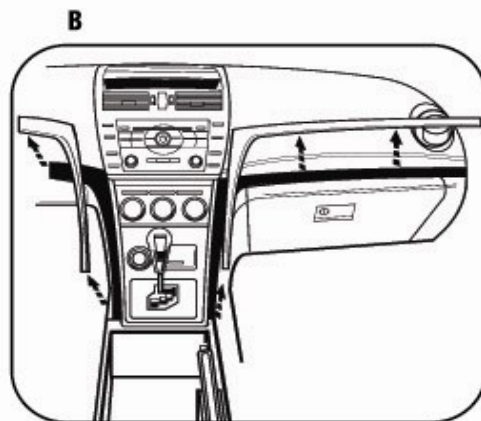
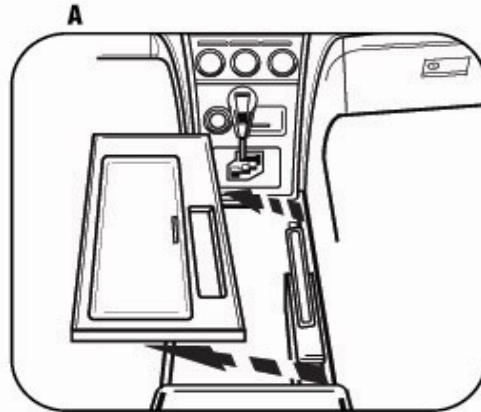
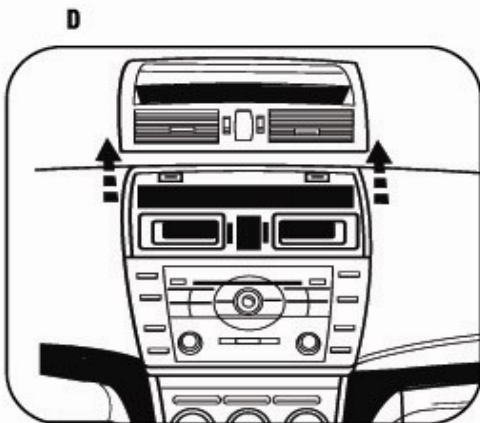

www.1999.gr

DOUBLE DIN/STACKED ISO MOUNT UNIT(S) PROVISION

**Note: Refer also to the instructions included with the aftermarket radio.*

- 1 Attach the filler trim panel to the back of the radio housing at the bottom edge. (Figure A)
- 2 Cut and remove the center bar from the Radio Housing. (Figure B)
- 3 Snap the Double DIN brackets to the inside edge of the Radio Housing. (Figure C)
- 4 Slide the Double DIN or stacked ISO mount unit(s) into the bracket/radio housing assembly and secure to the assembly using the screws supplied with the unit(s). Snap the DDIN Trim Plate onto the front of the Radio Housing. (Figure D)

Continue to final assembly.

